



# XEBHC-ACEU.0

English	Technical data
01 Power	0.13 kW   427 BTU/h
02 Frequency	50 / 60 Hz
06 Power supply cable type	H07RN-F
07 Voltage Power cable section Circuit breaker	220-240V ~1PH+N 3G x 0,75 mm <sup>2</sup> I1 1 A
08 Cable   Plug	Schuko
11 Water pressure	NaN-NaN kPa   NaN-NaN psi
14 IP protection class	

Italiano	Espanol
01 Potenza	01 Potencia
02 Frequenza	02 Frecuencia
06 Tipo cavo alimentazione	06 Tipo de cable de alimentación
07 Tensione Sezione cavi alimentazione Magnetotermico	07 Voltaje Sección del cable de alimentación Disyuntor
08 Cavo   Spina	08 Cable   Enchufe
11 Pressione acqua	11 Presión del agua
14 Grado protezione IP	14 Grado de protección IP

Français	Deutsch
01 Puissance électrique	01 Elektrische Leistung
02 Fréquence	02 Frequenz
06 Type de câble d'alimentation	06 Stromkabel Typ
07 Tension Section câbles d'alimentation Disjoncteur	07 Spannung Stromkabel Teil Sicherung
08 Câble   Prise	08 Leitung   Stecker
11 Pression de l'eau	11 Wasserdruck
14 Niveau de protection IP	14 IP-Schutzart

**Terms and conditions of installations** - Observe all local specific standard and regulations for installation and operations.



Русский	中文
01 Мощность	01 功率
02 Частота	02 频率
06 Тип силового кабеля	06 电源电缆类型
07 Напряжение Сечение силового кабеля Токовый автомат	07 电压 电源电缆截面 断路器
08 Кабель   Вилка	08 电缆和插头
11 Давление воды	11 水压
14 Класс защиты IP	14 IP保护等级

Português
01 Potência
02 Frequência
06 Tipo de cabo de alimentação
07 Tensão Seção de cabos de alimentação Disjuntor
08 Cabo   Plugue
11 Pressão da água
14 Grau de proteção IP

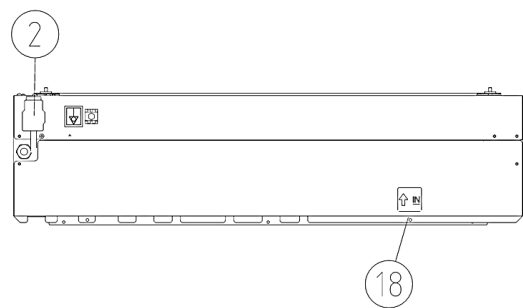
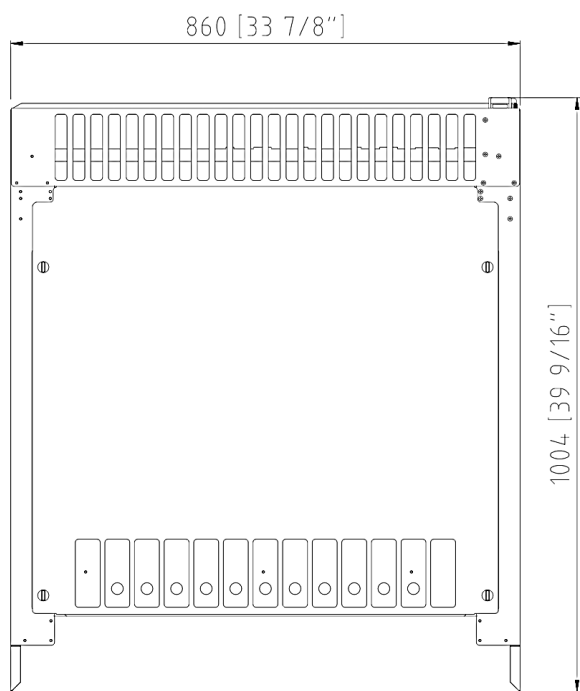
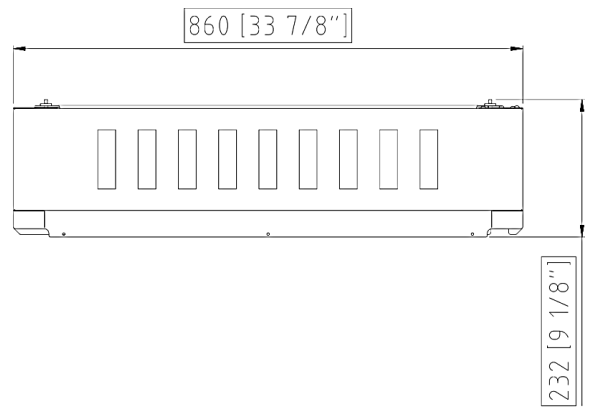
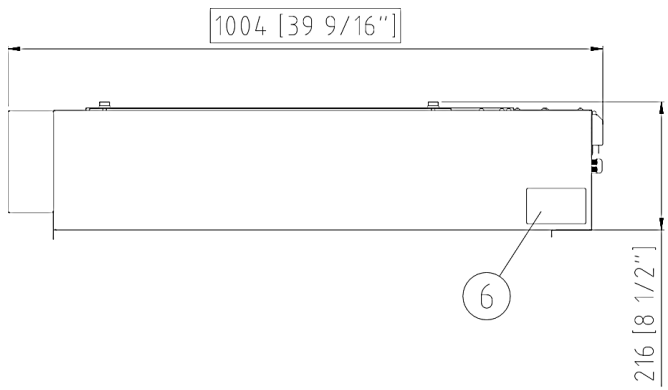



# XEBHC-ACEU.0

	English	Italiano	Español	Français	Deutsch
02	Electrical connection	Allacciamento elettrico	Conexión eléctrica	Raccordement électrique	Elektrischer Anschluss
08	Water connection	Allacciamento idrico	Conexión de agua	Raccordement à l'eau	Wasseranschluss
11	Water drain	Scarico acqua	Desagüe del agua	Evacuation	Abflussrohr
12	Smoke exhaust	Scarico fumi	Salida de humos	Aspiration des fumées	Abluftrohr
13	Accessories connection	Collegamento accessori	Conexión de accesorios	Connexion des accessoires	Anschluss des Zubehörs
31	Air inlet	Ingresso aria	Entrada de aire	Entrée d'air	Lufteinlass

	Русский	中文	Português
02	Электрическое подключение	电源连接	Conexão elétrica
08	Подключение к воде	水连接	Conexão hídrica
11	Выход воды	排水	Saída de água
12	Выход газов	排烟	Saída de fumaça
13	Подключение аксессуаров	配件连接	Conexão de acessórios
31	Воздухозаборник	空气入口	Entrada de ar

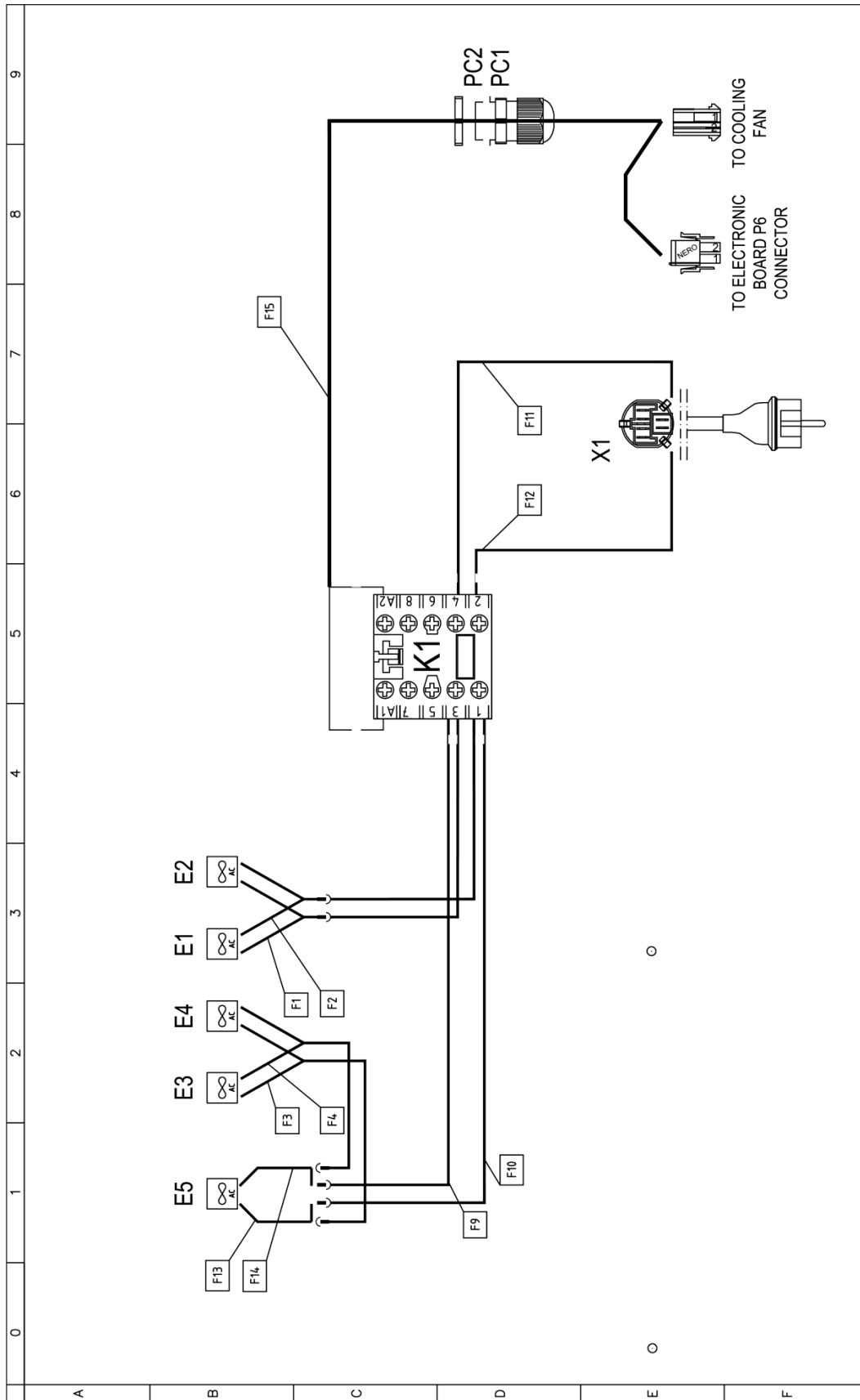

	0	1	2	3	4	5	6	7	8	9
A										
B										
C										
D										
E										
F										

Q	Sigle	Description	Descrizione	Description	Description	Beschreibung
	E1,E2,E3,E4,E5	COOLING FAN	VENTOLA RAFFREDDAMENTO	VENTILATEUR REFROIDISSEMENT	TURBINA DE REFRIGERACION	LÜFTER
	K1	CONTACTOR	TELERUTTORE	TELERUPTEUR	TELEARRUPTOR	RELAIS
	X1	CONTACTOR	MORSETTIERA	BOITE A BORNES	CONECTOR	KLEMMLEISTE